



مسقط لصناعة السخانات ش.م.و.
MUSCAT HEATERS
INDUSTRY LLC



Omani

The Technology Beyond Times

ELECTRIC WATER HEATERS

Company Profile

MUSCAT HEATERS INDUSTRY LLC is a member of Al Hosni Group International. The AL HOSNI GROUP was established in 1975. In a span of almost 33 years, the group has grown and diversified and is today a name that commands recognitions and respect in the sultanate of Oman and abroad

Whilst maintaining its commitment to contributing to the development of the nation, it has expanded its business activities throughout Oman and even abroad. Increasing our opportunities in the global market and emerging as a dynamic and prominent business house in the Sultanate of Oman. We started operation in Middle East, UK and Egypt as a model of a true Omani Multinational Company. The group has a long and close relationship with many leading companies in the Global Market.

The water heaters are manufactured using high quality raw materials and components imported from Italy. The modern manufacturing plant is managed by professionals and skilled technicians, who deliver high quality water heaters.

The water heaters are available in Galvanized Iron and Glasslined. We are very confident on the quality of our water heaters and have thereby offered long extended warranty.

The water heaters are manufactured as per Omani Standards and are certified by the DGSM, Ministry of Commerce and Industry in the Sultanate of Oman.

Our water heaters confirm to GSO standards (G Mark) and having Emirates Quality Mark by ESMA.

The company has certified ISO 9001:2015 Quality Management System

Our products are being sold in Oman, GCC, Middle East & African countries.

We wish to expand our operations to other countries like Libya, Syria, Egypt, Iraq, Russia and India etc. and appoint distributors who can promote and establish our range of products in the market.





- Single Weld Galvanized Iron Inner Tank
- High Quality Heating Element
- High Quality Automatic Thermostat
- Pressure Relief Valve For Extra Safety
- CFC Free Insulation Foam Saves Electricity
- Epoxy Polyester Powder Coated outer body

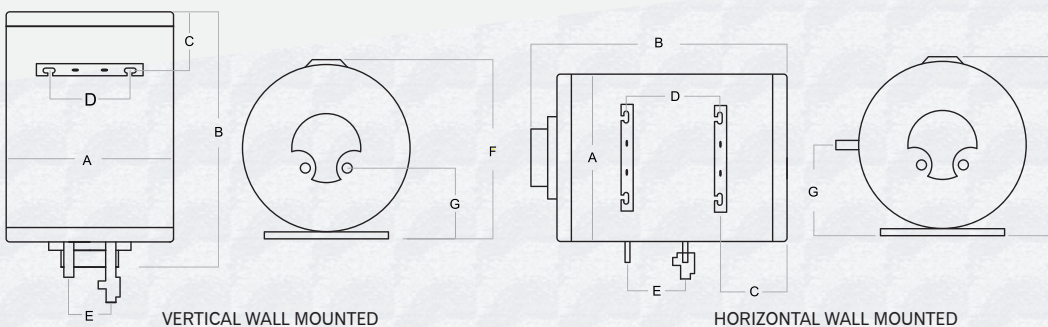

Technical Specification / Product Dimension (in mm)

Model No.	Water Capacity	A	B	C	D	E	F	G	PACKAGE Size(MM)	Gross Weight(KGS)
DF010V	10 Liters	290	340	95	230	100	310	55	340x340x375	6.920
DF015V	15 Liters	290	440	150	230	100	310	55	340x340x465	8.420
DF030V	30 Liters	400	465	125	270	100	435	110	425x425x550	15.400
DF030H	30 Liters	400	465	120	150	150	435	210	425x425x550	15.300
DF050V	50 Liters	400	635	180	235	100	435	110	475x475x675	18.300
DF050H	50 Liters	400	635	180	265	150	435	210	475x475x675	18.400

Rated Voltage	220 (V) - 240 (V)
Rated Input Power	1200 (W) / 1500 (W)
Power Frequency	50hz / 1PH
Set Temperature Maximum	75°C
Rated Pressure	7bar (MPa 0.7)
Inlet/Outlet Pipe Size	1/2" BSPT
Foam Insulation	20mm
Carton Thickness	5 Ply



Heating Element



Polyurethane
20mm Heat Resistant



Overheat Controller



Pressure Relief Valve



Thermometer



Earthing Protection



Anti Dry Heating
Protection



- High Quality Galvanized Iron Inner Tank
- High Quality Heating Element
- High Quality Automatic Thermostat
- Pressure Relief Valve For Extra Safety
- CFC Free Insulation Foam Saves Electricity
- Epoxy Polyester Powder Coated outer body

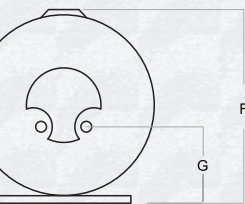
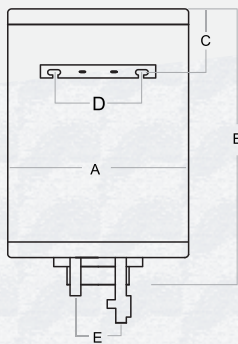

VERTICAL WALL MOUNTED

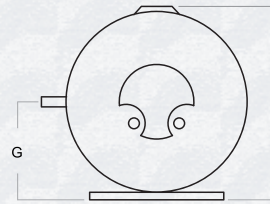
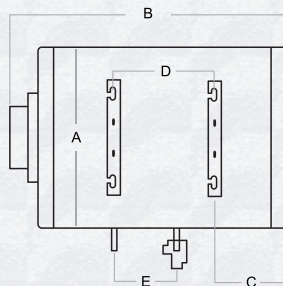

HORIZONTAL WALL MOUNTED



Technical Specification / Product Dimension (in mm)

Model No.	Water Capacity	A	B	C	D	E	F	G	PACKAGE Size(MM)	Gross Weight(KGS)
DF080V	80 Liters	450	770	195	260	100	485	150	475x475x820	22.880
DF080H	80 Liters	450	770	170	295	150	485	NA	475x475x820	23.000
DF100V	100 Liters	450	930	180	260	100	485	150	475x475x950	27.450
DF100H	100 Liters	450	930	185	455	150	485	NA	475x475x950	27.840

Rated Voltage	220 (V) - 240 (V)
Rated Input Power	1500 (W) / 2000 (W)
Power Frequency	50hz / 1PH
Set Temperature Maximum	75°C
Rated Pressure	7bar (MPa 0.7)
Inlet/Outlet Pipe Size	1/2" BSPT
Foam Insulation	20mm
Carton Thickness	5 Ply

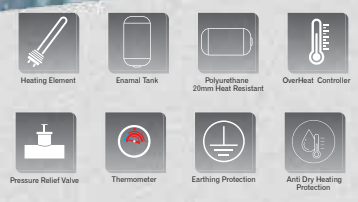

- High Quality Glass Lined (Enameled) Steel Inner Tank
- Double Safety Automatic Thermostat
- Pressure Relief Valve for extra safety
- Magnesium Anode for protection of inner boiler
- Stainless steel Inlet/Outlet pipe
- CFC free insulation foam saves Electricity
- Epoxy Polyester Powder coated outer body

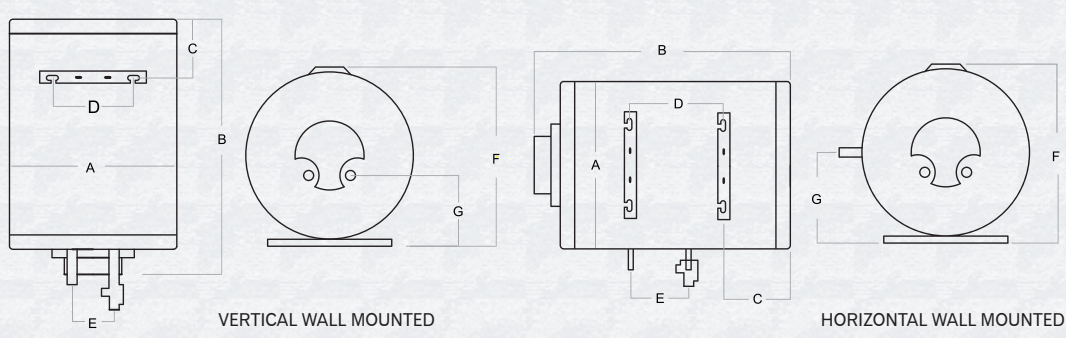

Technical Specification / Product Dimension (in mm)

Model No.	Water Capacity	A	B	C	D	E	F	G	PACKAGE Size(MM)	Gross Weight(KGS)
HW010V	10 Liters	290	340	95	230	100	310	55	340x340x375	14.600
HW015V	15 Liters	290	440	150	230	100	310	55	340x 340x465	15.100
HW030V	30 Liters	400	465	125	270	100	435	110	425x425x550	15.400
HW030H	30 Liters	400	465	120	150	150	435	210	425x425x550	15.300
HW050V	50 Liters	400	635	180	235	100	435	110	475x475x675	18.300
HW050H	50 Liters	400	635	180	265	150	435	210	475x475x675	18.400

Rated Voltage	220 (V) - 240 (V)
Rated Input Power	1200 (W) / 1500 (W)
Power Frequency	50hz / 1 PH
Set Temperature Maximum	75°C
Rated Pressure	7bar (MPa 0.7)
Inlet/Outlet Pipe Size	1/2" BSPT
Foam Insulation	20mm
Carton Thickness	5 Ply



- High Quality Glass Lined (Enameled) Steel Inner Tank
- Double Safety Automatic Thermostat
- Pressure Relief Valve for extra safety
- Magnesium Anode for protection of inner boiler
- Stainless steel Inlet/Outlet pipe
- CFC free insulation foam saves Electricity
- Epoxy Polyester Powder coated outer body

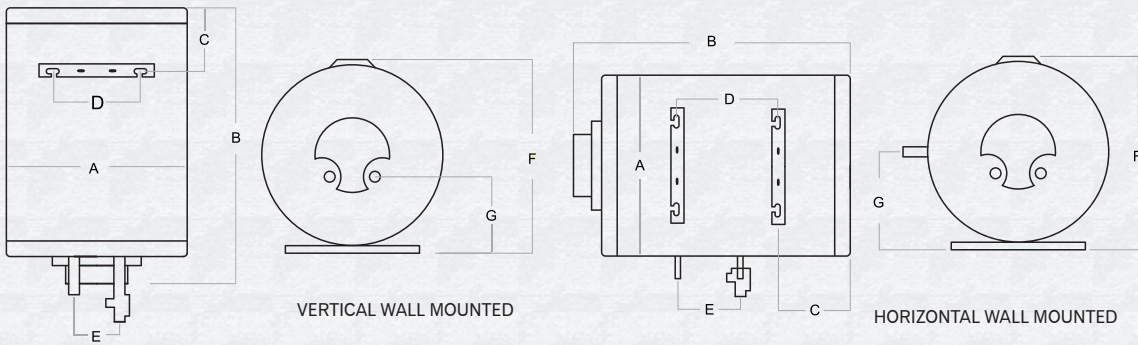

Technical Specification / Product Dimension (in mm)

Model No.	Water Capacity	A	B	C	D	E	F	G	PACKAGE Size(MM)	Gross Weight(KGS)
HW080V	80 Liters	450	770	195	260	100	485	150	475x475x820	22.880
HW080H	80 Liters	450	770	170	295	150	485	NA	475x475x820	23.000
HW100V	100 Liters	450	930	180	260	100	485	150	475x475x950	27.450
HW100H	100 Liters	450	930	185	455	150	485	NA	475x475x950	27.840

Rated Voltage	220 (V) - 240 (V)
Rated Input Power	1500 (W) / 2000 (W)
Power Frequency	50hz / 1PH
Set Temperature Maximum	75°C
Rated Pressure	7bar (MPa 0.7)
Inlet/Outlet Pipe Size	1/2" BSPT
Foam Insulation	20mm
Carton Thickness	5 Ply

Centralised Water Heater



- High Quality Glass Lined (Enamelled) Steel Inner Tank
- Double Safety Automatic Thermostat
- Pressure Relief Valve for extra safety
- Magnesium Anode for protection of inner boiler
- Stainless steel Inlet/Outlet pipe
- CFC free insulation foam saves Electricity
- Epoxy Polyester Powder coated outer body

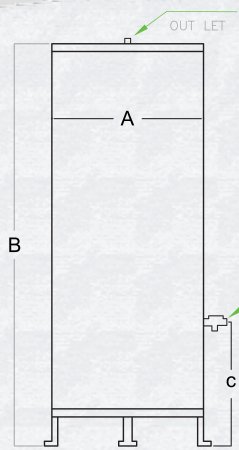

VERTICAL FLOOR MOUNT

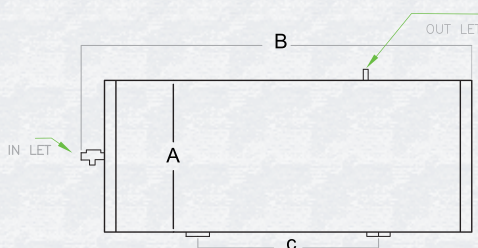

HORIZONTAL FLOOR MOUNT

Technical Specification / Product Dimension (in mm)

Model No.	Water Capacity	A	B	C	PACKAGE Size(MM)	Gross Weight(KGS)
HW150VFM	150 Liters	520	770	1035	ø520x1035	36.200
HW150HFM	150 Liters	520	770	990	ø520x990	37.200
HW200VFM	200 Liters	520	930	1305	ø520x1305	47.900
HW200HFM	200 Liters	520	930	1260	ø520x1260	46.900

Rated Voltage	220 (V) - 240 (V)
Rated Input Power	4000 (W) / 6000 (W)
Power Frequency	50hz / 1PH
Set Temperature Maximum	75°C
Rated Pressure	7bar (MPa 0.7)
Inlet/Outlet Pipe Size	¾" BSPT
Foam Insulation	20mm
Carton Thickness	2 Ply



Available in 30 & 50 Liters
**Easy to Fit Above
 False Ceiling**

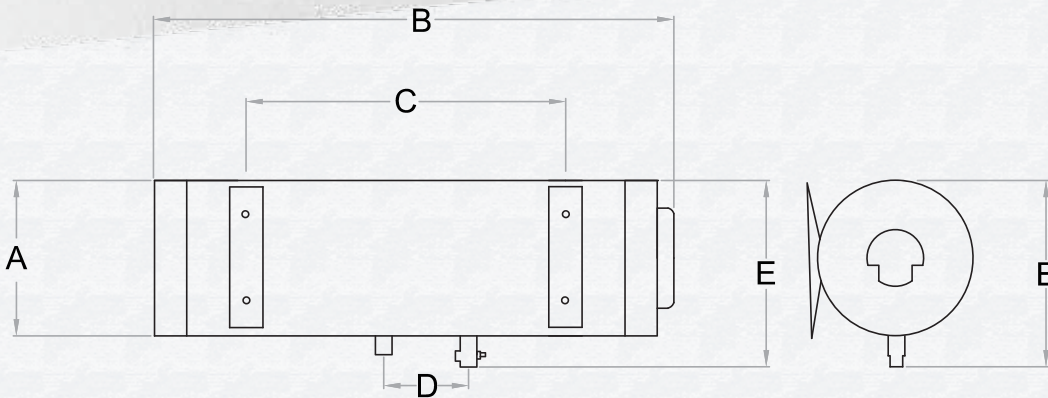

Technical Specification / Product Dimension (in mm)

Model No.	Water Capacity	A	B	C	D	E	PACKAGE Size(MM)	Gross Weight(KGS)
HW030SLH	30Liters	340	605	250	150	390	370x370x360	14.500
HW050SLH	50Liters	340	805	535	150	390	370x370x867	19.300

Rated Voltage	220 (V) - 240 (V)
Rated Input Power	1200 (W) / 1500 (W)
Power Frequency	50hz / 1PH
Set Temperature Maximum	75°C
Rated Pressure	7bar (MPa 0.7)
Inlet/Outlet Pipe Size	1/2" BSPT
Foam Insulation	20mm
Carton Thickness	5 Ply



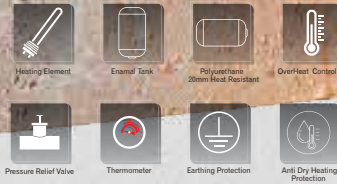

- High Quality Galvanized Iron Inner Tank
- High Quality Heating Element
- Automatic Thermostat
- Pressure Relief valve For Extra Safety
- CFC Free Insulation Foam Saves Electricity
- Epoxy Polyester Powder Coated outer body

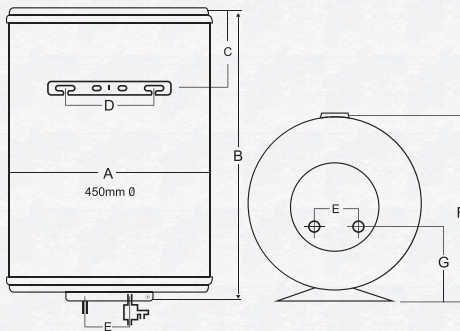

TYPE : VERTICAL WALL MOUNTED

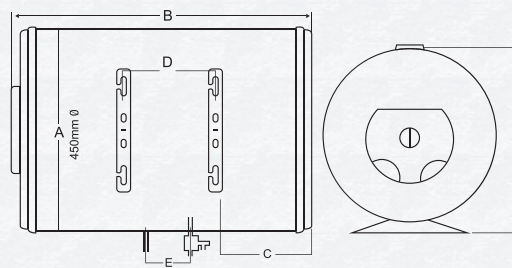

TYPE : HORIZONTAL WALL MOUNTED

Technical Specification / Product Dimension (in mm)

Model No.	Water Capacity	A	B	C	D	E	F	G	CARTON Size(MM)	Gross Weight(KGS)
FJR050V	50 Liters	450	560	230	260	100	485	170	475x475x565	14.600
FJR050H	50 Liters	450	560	105	235	150	455	N/A	475x475x565	15.100
FJR080V	80 Liters	450	770	190	265	100	455	165	475x475x780	19.780
FJR080H	80 Liters	450	770	170	360	150	455	N/A	475x475x780	19.780
FJR100V	100 Liters	450	920	150	500	100	450	165	475x475x985	26.500
FJR100H	100 Liters	450	920	150	500	150	450	N/A	475x475x985	26.500

Rated Voltage	220 (V) - 240 (V)
Rated Input Power	1500 (W) / 2000 (W)
Power Frequency	50hz / 1PH
Set Temperature Maximum	75°C
Rated Pressure	7bar (MPa 0.7)
Inlet/Outlet Pipe Size	1/2" BSPT
Foam Insulation	20mm
Carton Thickness	5 Ply



Price Buster Water Heater

Special Features

- Single Weld Galvanized Inner Tank
- High Quality Copper Heating Element
- High Quality Automatic Thermostat
- Pressure Relief Valve For Extra Safety
- Epoxy Polyester Powder Coated
- Insulation Provided



EXPORT ONLY

Available in Vertical and Horizontal wall mounting

SPECIFICATIONS	SUNSTAR - 12	SUNSTAR - 16
Dia (m.m.)	400	400
Height (m.m.)	531	625
Carton Dimension (m.m.)	425 x 425 x 550	425 x 425 x 710
Volt / Watt	220 - 240V / 1200	W - 50 Hz / 1Ph

ELECTRIC WATER HEATER

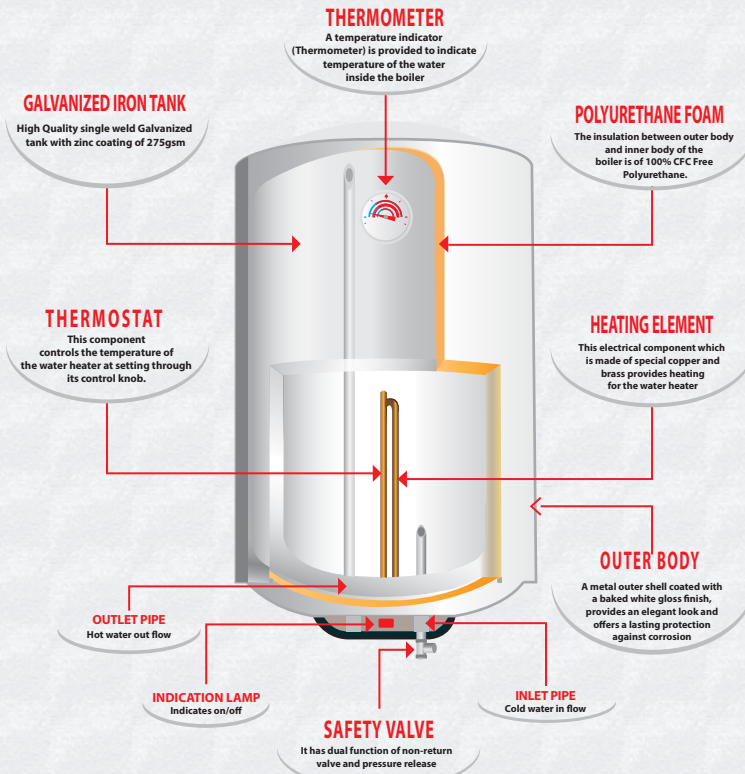

GLASS LINED WATER HEATER

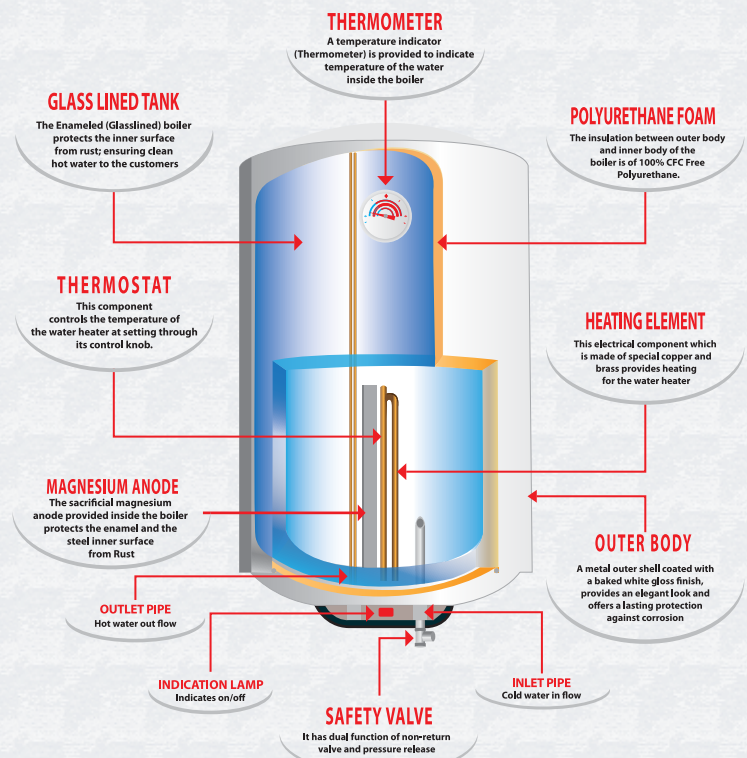



ELECTRIC WATER HEATERS

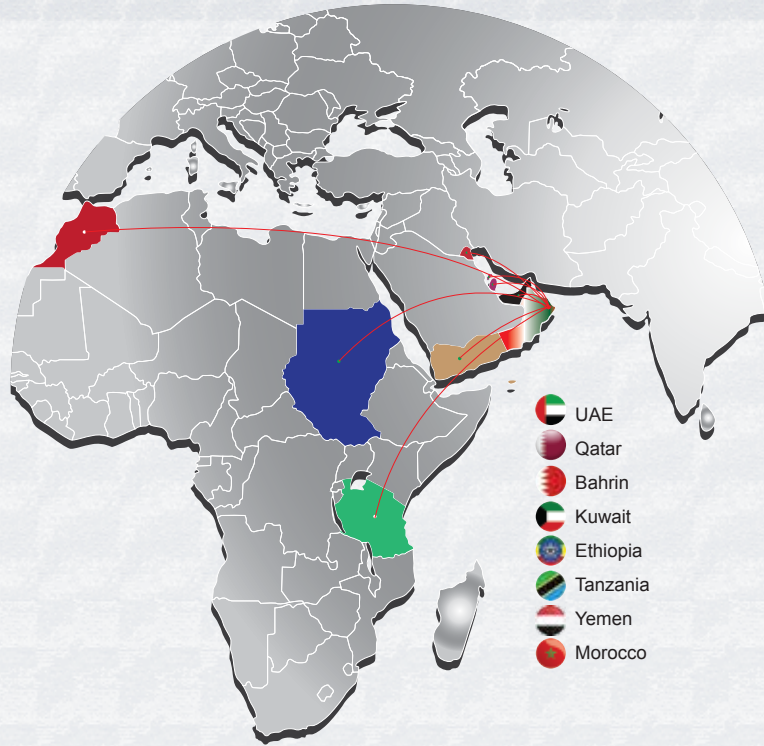

www.muscatheaters.com



مسقط لصناعة السخانات ش.م.و.
MUSCAT HEATERS
INDUSTRY LLC

Rusayl, Sultanate of Oman
Tel: (+968) 22005703-4, Fax: (+968) 22005701-2
GSM : (+968) 93200419 , 99849560 , 93209223
Email: mhic@alhosnigroup.com

